

LIFTKAR® PT

SANO
makes life easier.

**Electric-powered stairclimbers for
people with walking difficulties**

Liftkar **PT-S** 130/160

Liftkar **PT-Outdoor** 120/150

Liftkar **PT-Uni** 130/160

Liftkar **PT-Fold** 130/160

Liftkar **PT-Plus** 115

Liftkar **PT-Adapt** 130/160

Instruction manual

SANO Transportgeraete GmbH

Am Holzpoldlgut 22

4040 Linz/Lichtenberg

Austria

Tel.: +43 (0) 7239 / 510 10

Fax: +43 (0) 7239 / 510 10 14

office@sano.at

www.sano.at



issued:04/2011 - subject to updates - en

Contents

1	Introduction	4
2	General safety guidelines	4
3	Description / Technical data	6
3.1	PT-S model with integral seat	6
3.1.1	Technical data for PT-S model	6
3.1.2	Scope of supply for model PT-S	7
3.2	PT-Outdoor model with integral seat	7
3.2.1	Technical data for PT-Outdoor model	8
3.2.2	Scope of supply for model PT-Outdoor	8
3.3	PT-Universal model for a wide range of wheelchairs	8
3.3.1	Technical data for PT-Universal model	10
3.3.2	Scope of supply for model PT-Universal	10
3.4	PT-Fold model	11
3.4.1	Technical data for PT-Fold model	11
3.4.2	Scope of supply for model PT-Fold	12
3.5	PT-Plus model (plus wheelchair)	12
3.5.1	Technical data for PT-Plus model	13
3.5.2	Scope of supply for model PT-Plus	13
3.6	PT-Adapt model	14
3.6.1	Technical data for PT-Adapt model	14
3.6.2	Scope of supply for model PT-Adapt	15
3.7	Technical data applying to all models	15
3.8	Technical data for battery pack	17
3.9	Names of main parts	18
3.9.1	Handle unit	18
3.9.2	Battery pack	19
3.9.3	Climber unit	19
4	Control features	20
4.1	Control cluster at top end of handle unit column	20
4.1.1	Main switch 1	20
4.1.2	Speed selector switch 2	20
4.1.3	Mode switch 3	21
4.1.4	LED display 4	21
4.1.5	Beeper function for correct transport angle	21
4.2	UP/DOWN switch left and right on handle	22
4.3	Clamping nut on adjustable handle	22
5	Preparations to be made before you start	23
5.1	Climber unit, battery pack and handle unit	23
5.1.1	Adjust handle	24
5.1.2	Headrest (optional)	24
5.2	Additional preparations (depending on model)	25
5.2.1	Adjust seat position on Liftkar PT-S and PT-Outdoor models	25
5.2.2	Loading a wheelchair onto a Liftkar PT-Universal (<i>general information</i>)	26
5.2.3	How to load a self-propelled wheelchair (<i>PT-Universal</i>)	28
5.2.4	How to load a transport wheelchair (<i>PT-Universal</i>)	30

5.2.5	How to unload a self-propelled wheelchair (<i>PT-Universal</i>)	31
5.2.6	How to unload a transport wheelchair (<i>PT-Universal</i>)	32
5.2.7	Loading a wheelchair onto a Liftkar PT-Plus and PT-Adapt	33
5.2.8	Detaching the Liftkar PT-Plus and PT-Adapt from the wheelchair	35
6	Operation on stairs	36
6.1	General instructions for operating on stairs	36
6.2	Climbing UP stairs	37
6.3	Climbing DOWN stairs	39
6.4	Operation on spiral staircases	40
6.5	Parking the Liftkar PT on the stairs	41
6.6	Ideal transport angle	41
6.7	Getting on and off the stairclimber	41
7	Operation on a ramp	42
7.1	Moving DOWN a ramp	42
7.2	Moving UP a ramp	42
8	Charging the battery pack	42
8.1	Charger unit	43
8.1.1	Technical data	44
8.1.2	Safety guidelines	44
8.1.3	Use only for the purpose intended	44
8.2	Mobile charger (optional)	45
8.2.1	Technical data	45
8.2.2	Safety guidelines	45
8.2.3	Use only for the purpose intended	46
8.3	Connecting charger unit to battery pack	46
8.4	CE mark for charger units	46
9	Care, maintenance and transport	47
9.1	Maintenance	47
9.2	Cleaning	49
9.3	Battery pack	49
9.4	Brakes and inside rims of main wheels	49
9.5	Spares and repairs	49
9.6	Transport	49
9.7	Disposal	50
9.8	Re-use / Second-hand use	50
10	Troubleshooting	51
11	Warranty and product liability	51
11.1	Warranty	51
11.2	Product liability	52
11.3	Declaration of conformity	52
11.4	Registered patents	52

1 Introduction

Congratulations!

Your new Sano Liftkar PT provides you with an easy method of conveying wheelchair users up and down stairs safely. The Liftkar PT is a mobile stairclimber, meaning you can take it with you to use on any stairs. Liftkar gives you more freedom as a result. At the same time, helpers no longer need to strain their backs on the stairs.

Releasing a lever that is easily accessible without the operator having to bend down lets the Liftkar PT be dismantled into 3 handy parts: the climber unit (15 kg) and the battery pack and handle unit (4 kg each). All parts are easy to stow away because they are lightweight and compact.

On stairs the Liftkar PT is remarkably smooth to operate and safe to handle. As a mobility provider, partner, relative or friend, Sano wishes you all the best in using this stairclimber. We hope you will find this instruction manual useful in finding out how to operate your Liftkar PT.

2 General safety guidelines

- Read these instructions carefully. Make sure you comply with all instructions in this manual and on signs fitted to the equipment. Climbing stairs presents a risk in itself and not complying with these instructions could cause accidents.
- The stairclimber may only be used for the purpose for which it has been designed – transporting people on stairs.
- The Liftkar PT may only be operated by people who
 - have proof of having been trained in how to operate the stairclimber
 - can walk up stairs backwards
 - are both physically and mentally sound
 - are able to maintain balance without great physical strain.
- Never operate the Liftkar PT on surfaces that are wet, slippery, polished or waxed, smooth, icy or generally do not give the operator sufficient stability, and impair the braking performance of the brakes on the transport wheels. Rugs and carpets can also present a risk.
- Under no circumstances may you let go of the handle while operating the stairclimber on the stairs.
- Make sure that nobody is below the Liftkar PT while in operation on stairs.

- A safety belt must always be used when transporting people with Liftkar stairclimbers.
The safety belt must always be closed while the stairclimber is in operation, regardless of whether a person is being transported or not. Never allow the safety belt to hang over the side to the left or right. Risk of jamming the wheels – danger of falling. Risk of damaging the stairclimber.
- For transporting people using Liftkar stairclimbers, only use wheelchairs fitted with a safety belt or other personnel retention system.
- Passengers who are not able to sit securely will need to wear a belt.
- **Make sure you always wear closed, non-slip shoes when operating the Liftkar PT.**
- Do not use the Liftkar PT with a passenger until you have practised operating it perfectly without a payload. Next, try operating it again with somebody as lightweight as possible who is not disabled. The test passenger should hold onto a handrail or a second person during the climb.
- Always start by using the lowest speed first (setting 1). Do **not** switch from single step mode to continuous mode.
- Never reach into the transport mechanism with your hands while the battery pack is connected. (Risk of snagging/squashing).
- When transporting the Liftkar PT itself, Sano recommends undoing the lever screw (stays on handle, so there is no risk of losing it) and taking the stairclimber apart. This will prevent it from being switched on inadvertently and in this form the Liftkar PT is easier to transport.
- The Liftkar PT is supplied with a powerful, replaceable 5 Ah / 24 Volt battery pack, which should always be fully charged before using the stairclimber. If, for whatever reason, the battery pack should run out of power while in operation on stairs, move the stairclimber down the stairs and replace or recharge the battery. It is always possible to move down at least one flight of stairs, even with an empty battery pack. The first sign of the battery pack running out is indicated by the stairclimber's performance. The Liftkar PT becomes slower and appears to be struggling. Inexperienced operators are warned by the LED display: if the battery pack needs to be recharged the LED display starts flashing, alternating between red and green and an intermittent acoustic warning signal.
- Do not use the stairclimber if unusual noises and/or vibrations occur while the Liftkar stairclimber is in operation. Withdraw the stairclimber from use and have it inspected by an authorised specialist.
- Please observe the following instructions regarding storing and operating your Liftkar stairclimber:
Avoid exposing the stairclimber to high temperatures such as direct sunlight and high humidity, e.g. due to use in saunas, etc, because there is a risk of overheating, burning and damaging the stairclimber. Avoid exposing the stairclimber to very low temperatures below 5°C.

3 Description / Technical data

3.1 PT-S model with integral seat

Stair-climbing transport chair with adjustable backrest and armrests attached to the handle unit. The handle unit, battery pack and climber unit can be quickly dismantled by releasing a single lever screw (stays on handle, so there is no risk of losing it). The seat folds down to save space. Two versions are available for a passenger weight of 130 kg and 160 kg.

Highly suitable for very steep and narrow spiral staircases because there is plenty of clearance with the compact design of seat and main wheels just 200 mm in diameter.

Liftkar **PT-S** 130 item no. 045 723
Liftkar **PT-S** 160 item no. 045 724



3.1.1 Technical data for **PT-S** model

- **Safe working load:** 130 kg (PT-S 130)
(passenger weight) 160 kg (PT-S 160)
- **Wheel diameter:** 200 mm
- **Track width (outside):** 297 mm
- **Weight (total):** 30,5 kg
- **Weight (climber unit + seat):** 18,5 kg
- **Overall height:** 1130 mm
- **Overall width:** 505 mm (incl. armrests)
- **Overall length:** 675 mm (600 mm with seat and armrests folded away)

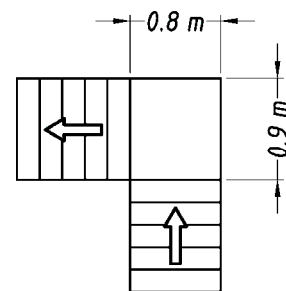

Space requirements on landings

3.1.2 Scope of supply for model **PT-S**

On delivery the box should contain the following components:

- Climber unit
- Handle unit incl. seat, backrest and folding armrests
- Battery pack
- Charger
- Instruction manual

If one of these components is missing or damaged, please contact the dealer who supplied the stairclimber.

3.2 **PT-Outdoor** model with integral seat

Stair-climbing transport chair like PT-S (see 3.1), but with **260 mm diameter wheels** and **430 mm track width**. Robust 100 mm diameter automatic step edge brake wheels within main wheels; moves quietly effortlessly negotiates steps up to a height of 25 mm. With the automatic step brake wheels located on the inside there is no risk of collisions with door frames and damage is avoided.

Thanks to its large diameter main wheels this unit operates very well outdoors on uneven ground. Extra stability on slopes is provided by the wider track width.

Liftkar **PT-Outdoor** 120.....item no. 045 725

Liftkar **PT-Outdoor** 150.....item no. 045 726



3.2.1 Technical data for PT-Outdoor model

- **Safe working load:** 120 kg (PT-Outdoor 120)
150 kg (PT-Outdoor 150)
- **Wheel diameter:** 260 mm
- **Track width (outside):** 430 mm
- **Weight (total):** 34,3 kg
- **Weight (climber unit + seat):** 22,3 kg
- **Overall height:** 1130 mm
- **Overall width:** 505 mm (*incl. armrests*)
- **Overall length:** 675 mm (*600 mm with seat and armrests folded away*)

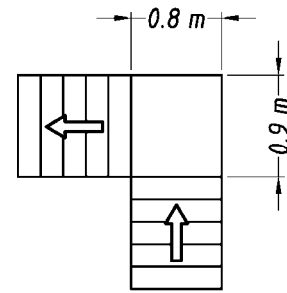

**Space requirements
on landings**

3.2.2 Scope of supply for model PT-Outdoor

On delivery the box should contain the following components:

- Climber unit with large wheels (diameter 260 mm)
- Handle unit incl. seat, backrest and folding armrests
- Battery pack
- Charger
- Instruction manual

If one of these components is missing or damaged, please contact the dealer who supplied the stairclimber.

3.3 PT-Universal model for a wide range of wheelchairs

This model enables you to transport any wheelchair (including sports wheelchairs) up stairs without any modifications to the wheelchair, complete, **without removing its wheels**. Features folding platforms on either side for supporting the wheels of the wheelchair and a handy, easy-to-use adjustable retainer which clamps the backrest in place (*maximum width 495 mm*). Suitable for every standard make of transport wheelchair and self-propelled wheelchair. **An advantage here is that the wheels of the wheelchair do not need to be removed.** Suitable for professional mobility providers and private users. Takes up slightly more space on the staircase than the other models. Loading and unloading the wheelchair takes less than a minute at each end of the journey. This model is also highly suitable for transporting children's wheelchairs.

Note: with some wheelchairs it may be necessary to raise or remove any anti-tip devices. If the anti-tip devices are fixed then they will need to be modified to the removable or foldable type.

Liftkar PT-Universal 130 item no. 045 727
Liftkar PT-Universal 160 item no. 045 728

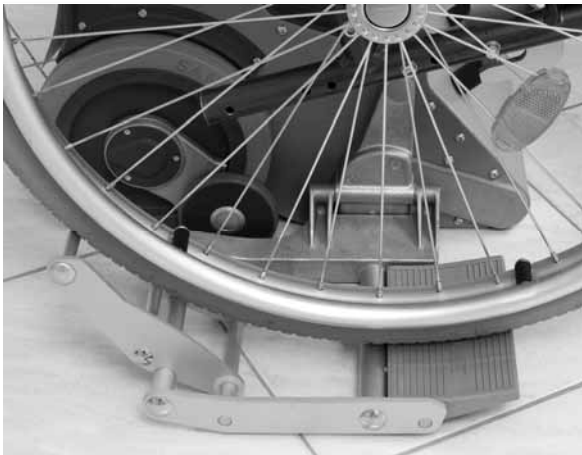

3.3.1 Technical data for **PT-Universal** model

- **Safe working load:** 130 kg (PT-Universal 130)
(incl. wheelchair) 160 kg (PT-Universal 160)
- **Maximum width of backrest:** 495 mm
- **Maximum track width of wheelchair:** 730 mm (measured on outside of wheels)
- **Wheel diameter:** 200 mm
- **Track width (outside):** 297 mm
- **Weight (total):** 27,6 kg
- **Weight (climber unit):** 16,7 kg (incl. side platforms)
- **Overall height:** 1130 mm
- **Overall width:** 760 mm (with side platforms down)
395 mm (with side platforms up)
482 mm (handle unit)
- **Overall length:** 385 mm

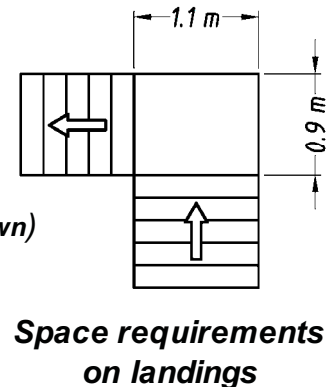

3.3.2 Scope of supply for model **PT-Universal**

On delivery the box should contain the following components:

- Climber unit with folding side platforms
- Handle unit including backrest clamp
- Battery pack
- Charger
- Instruction manual

If one of these components is missing or damaged, please contact the dealer who supplied the stairclimber.

3.4 PT-Fold model

This is the straightforward solution for transporting patients. With 200 mm diameter wheels and a track width of just 297 mm the PT-Fold is ideal for very steep and narrow spiral staircases.

The washable seat cover can be wiped clean and removed by simply undoing a zip. While you are not using the Liftkar PT it can be simply folded away! Saves space at work and on the road.

Liftkar PT-Fold 130	item no. 045 731
Liftkar PT-Fold 160	item no. 045 732



3.4.1 Technical data for **PT-Fold** model

- **Safe working load:** 130 kg (PT-Fold 130)
(passenger weight) 160 kg (PT-Fold 160)
- **Wheel diameter:** 200 mm
- **Track width (outside):** 297 mm
- **Total weight:** 28 kg
- **Height:** 1130 mm
- **Width:** 430 mm (seat)
482 mm (handle unit)
- **Depth:** 660 mm (405 mm with seat folded up)

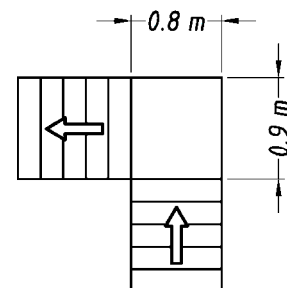

**Space requirements
on landings**

3.4.2 Scope of supply for model **PT-Fold**

On delivery the box should contain the following components:

- Stairclimber complete
(consisting of climber unit, battery pack, handle unit and folding seat)
- Charger
- Instruction manual

If one of these components is missing or damaged, please contact the dealer who supplied the stairclimber.

3.5 **PT-Plus** model (plus wheelchair)

Stairclimber plus high-quality wheelchair (self-propelled) with integrated adapter. The stairclimber can be attached and detached. Can be used on the level as a normal wheelchair, even with the stairclimber unit still attached. To move up stairs the wheelchair wheels, which feature slot-in axles, are relocated to a higher position (see photo). As a result there is sufficient clearance for climbing the stairs and the wheels remain with the wheelchair.

The wheelchair itself is very stable, and yet can easily be folded away compactly.

Features:

- Removable feet supports with footplates that are height- and angle-adjustable.
- Removable folding armrests
- Seat cushion 457 mm wide and 430 mm deep

Liftkar **PT-Plus** 115item no. 045 729



3.5.1 Technical data for **PT-Plus** model

- **Safe working load:** 115 kg
(passenger weight)
- **Wheel diameter:** 200 mm
- **Track width (outside):** 297 mm
- **Weight (total):** 23,5 kg
- **Weight (climber unit):** 14 kg
- **Overall height:** 1130 mm
- **Overall width:** 430 mm (without wheelchair)
- **Overall length:** 385 mm (without wheelchair)

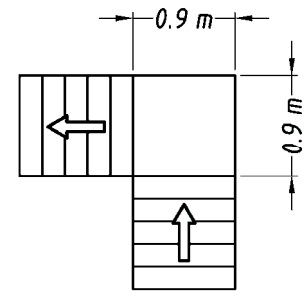

**Space requirements
on landings**

Wheelchair:

- **Width of seat:** 450 mm
- **Diameter of wheels:** 610 mm
- **Weight of wheelchair:** 18 kg

3.5.2 Scope of supply for model **PT-Plus**

On delivery the box should contain the following components:

- Climber unit
- wheelchair WTB incl. adapters
- Handle unit
- Battery pack
- Charger
- Instruction manual

If one of these components is missing or damaged, please contact the dealer who supplied the stairclimber.

3.6 PT-Adapt model

Stairclimber for accommodating wheelchairs using adapters. Two versions available with safe working loads of 130 kg and 160 kg including wheelchair.

Liftkar **PT-Adapt** 130item no. 045 721

Liftkar **PT-Adapt** 160item no. 045 722



3.6.1 Technical data for PT-Adapt model

- **Safe working load:** 130 kg (PT-Adapt 130)
(incl. wheelchair) 160 kg (PT-Adapt 160)
- **Minimum wheelchair width (inside frame):** 320 mm
- **Wheel diameter:** 200 mm
- **Track width (outside):** 297 mm
- **Weight (total):** 24,7 kg
- **Weight (climber unit):** 15,2 kg
- **Overall height:** 1130 mm
- **Overall width:** 482 mm (without wheelchair)
- **Overall length:** 385 mm (without wheelchair)

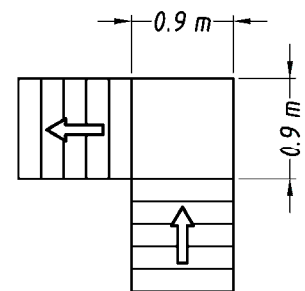

Space requirements on landings

3.6.2 Scope of supply for model **PT-Adapt**

On delivery the box should contain the following components:

- Climber unit
- Handle unit
- Battery pack
- Charger
- Instruction manual

If one of these components is missing or damaged, please contact the dealer who supplied the stairclimber.

Important:

Your wheelchair must be fitted with special adapters before it can be transported using the Liftkar PT stairclimber. Please contact your dealer immediately if this is not the case.

3.7 Technical data applying to all models

- **Climbing speed:** three speeds can be selected on the control cluster:
 - I = 10 steps per minute
 - II = 14 steps per minute
 - III = 18 steps per minute
- **Maximum step height:** 205 to 220 mm (*the maximum is achieved by tilting the stairclimber at a steeper angle*)
- **Range per recharge:** depends a lot on weight of passengers and whether they are travelling up or down. However, between 300 and 500 steps can be specified as a rough guide. If the stairclimber is in constant use, (e.g. professional mobility services) then a replacement battery pack can be fitted at any time. A mobile charger (see 8.2.) is also available to rapidly charge the battery pack during the car journey.
- **Protection against overloading:**
 - 1) Mechanical overload protection (*sliding hub*)
 - 2) Electronic overload protection
- **Electrical data**

Protection class	IPX4
Nominal voltage	24 VDC
Max. current	30 A

Data for electromagnetic compatibility (EMC)

EMV-Allgemeine Daten			
Emission		Übereinstimmung	
RF-Emission according EN 55011		group 1	
RF-Emission according EN 55011		Class B	
Generation of mains harmonics following IEC 61000-3-2		Battery operation, not applicable	
Generation of mains harmonics following IEC 61000-3-3		Battery operation, not applicable	
EMV-Tabelle 202			
Susceptibility	IEC 60601-test level	actual level	
ESD IEC 61000-4-2	±6kV cd ±8kV ad	±2kV, ±4kV ±6kV cd ±8kV ad	
Bursts IEC 61000-4-4	±2kV mains ±1kV I/O	Battery operation, not applicable	
Surges IEC 61000-4-5	±1kV dm ±2kV cm	Battery operation, not applicable	
Voltage drops etc. IEC 61000-4-11	Reduction to	Reduction to	
	5% for 10ms/ positive amplitude	Battery operation, not applicable	
	5% for 10ms/ negative amplitude	Battery operation, not applicable	
	40% for 100ms	Battery operation, not applicable	
	30% for 500ms	Battery operation, not applicable	
0% for 5000ms	Battery operation, not applicable		
H-field at 50/60Hz IEC 61000-4-8	3A/m	no magnetically sensitive sensors or parts, not applicable	
EMV-Tabelle 204			
Susceptibility	IEC 60601-test level	Actual level	
Conducted RF IEC 61000-4-6	3V _{eff} 150kHz to 80 MHz	3V _{eff}	
Radiated RF IEC 61000-4-3	3V/mf 80 MHz to 2,5 GHz	3V/m	
EMV-Tabelle 206			
Output power of transmitter W	Safety distance depending on frequency/m		
	150kHz to 80MHz	80MHz to 800MHz	800MHz to 2,5 GHz
0,01	0,12m	0,12m	0,24m
0,1	0,37m	0,37m	0,74m
1	1,17m	1,17m	2,34m
10	3,69m	3,69m	7,38m
100	11,67m	11,67m	23,34m

Note on electromagnetic compatibility (EMC)

The electric motors corresponds with the protection requirements laid down in the European Council Directive on the legal regulations of the member states concerning electromagnetic compatibility (EMC) (2004/108/EC). However, it can not be completely excluded that under certain conditions an electrical malfunction occurs, especially in connection with the use of mobile phones. Do not operate the stairclimber near life support systems or equipment that could injure users if it fails. These could be negatively affected under certain conditions, and trouble-free operation of the stairclimber may be impaired. If you notice the stairclimber malfunctioning or behaving strangely near other electrical equipment then remove the stairclimber from service and have it inspected by a specialist dealer.

3.8 Technical data for battery pack

Weight of battery: 4,3 kg
Capacity: 5,2 Ah
Voltage: 24 VDC
(2x 12 VDC – 5,2 Ah)



Type of battery: maintenance-free, leak-safe lead gel cell (approved by DOT and IATA for air freight)
Fuse: internal fuse (30 Amp) and electronic cut-out at charging contact
Charging contact: DC jack \varnothing 2,1 x 9,5 mm
Power outlet: via 2 robust flat contacts to two spring-loaded contacts on the climber unit

3.9 Names of main parts

3.9.1 Handle unit

Handle unit column **1**

Adjustable handle **2**

Clamping nut for adjusting handle **3**
(*control feature*)

Crossbar **4**

Lever screw **5**

Control cluster **6** (*control feature*)

UP/DOWN switch **7** (*control feature*)



3.9.2 Battery pack

Charging socket 1

Power outlet 2

Carrying handle 3

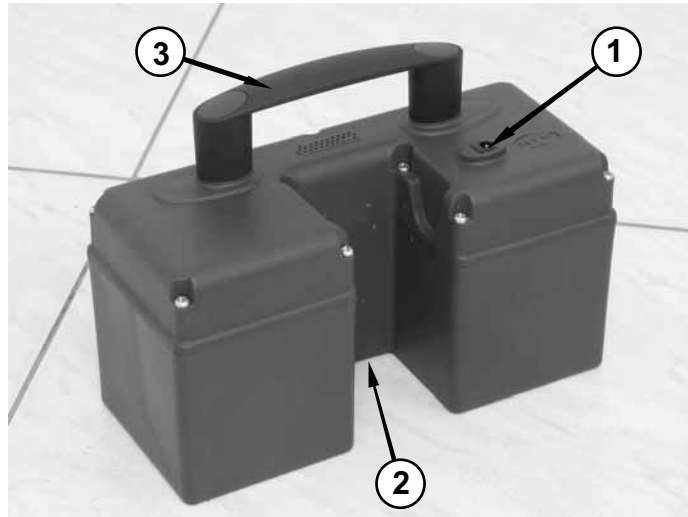

3.9.3 Climber unit

Lifting frame 1

Support wheels on lifting frame 2

Main wheels 3

Automatic step edge brakes 4

Spring-loaded contacts to battery power outlet 5

Mounting socket for handle unit column 6

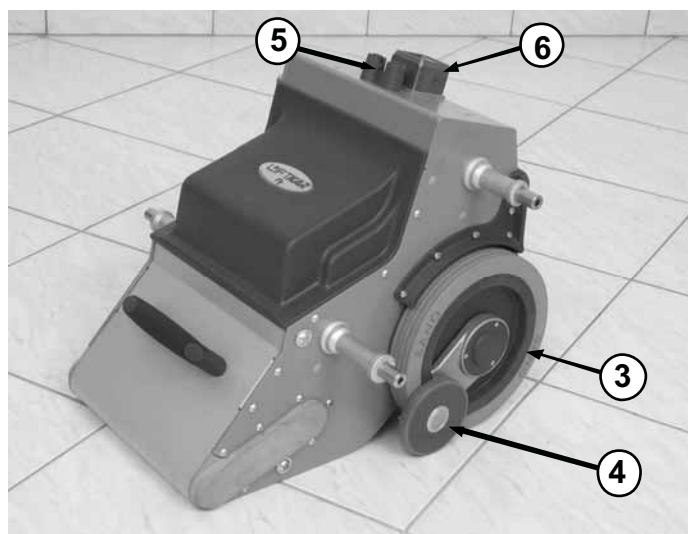
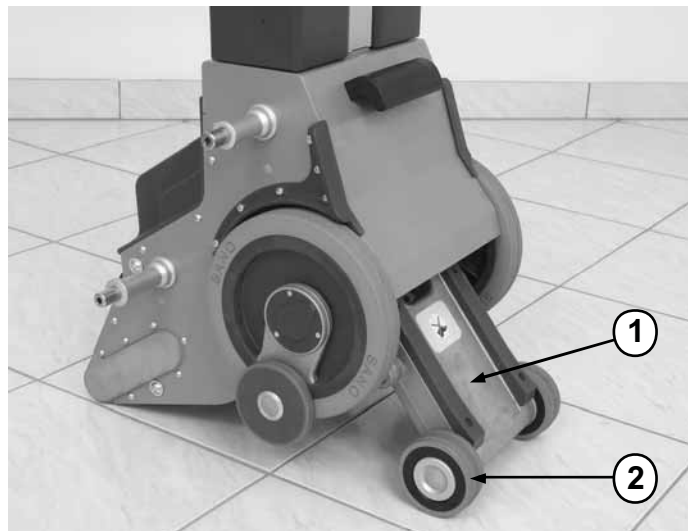

4 Control features

4.1 Control cluster at top end of handle unit column

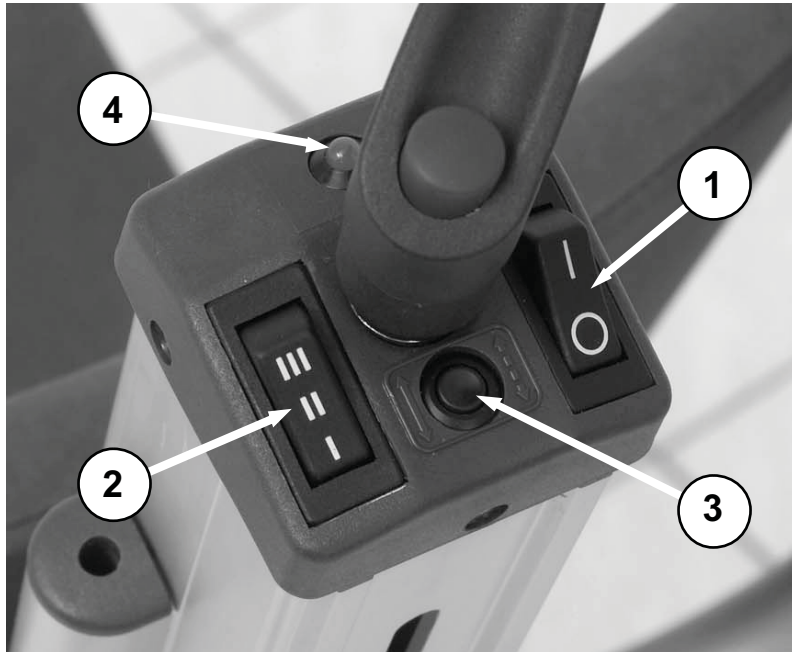

4.1.1 Main switch (1)

Use this switch to switch the stairclimber on via a safety circuit. Press it again to switch off. The Liftkar PT switches itself off automatically after 10 minutes.

4.1.2 Speed selector switch (2)

Use this switch to choose the climbing speed of the lifting frame mechanism. (See *section 3.7 for absolute figures*)

I: Slow
II: Medium
III: Fast

4.1.3 Mode switch (3)

Use this mode switch to switch between **single-step mode** and continuous mode and back to *single-step mode*.

*For safety reasons, **single-step mode** is always selected first each time the main switch on the Liftkar PT is switched on. In this mode the lifting frame and support wheels come to a halt in a neutral position between the main wheels after each complete step cycle has been completed. The next step cycle is started by pressing the UP/DOWN switch (4.2) again.*

Operators should not switch over to continuous mode unless they are in complete control of the stairclimber and the stairs are easy to negotiate. In this mode the UP/DOWN switch does not need to be pressed for each step.

4.1.4 LED display (4)

The LED display gives a clear indication of the status of the Liftkar:

Green (not flashing): normal and in single-step mode.

Flashing green: Warning! Continuous mode is switched on. Otherwise normal.

Red (not flashing): The Liftkar PT is at too flat an angle to the rear or leaning too far forward. If the angle is not upright enough the angle sensor blocks operation of the climbing mechanism. Pressing one of the UP/DOWN switches causes the LED to display red. If the transport angle is too steep the sensor switches off the climbing function and the LED displays red as long as the UP/DOWN switch is pressed.

Flashing red: the stairclimber is overloaded and the electronic overload protection stops the Liftkar PT. *(The LED flashes until you let go of the UP/DOWN switch. Pressing the UP/DOWN switch again allows you to continue up or down).*

Alternating red and green: the battery pack is running low and urgently needs to be recharged. The stairclimber will certainly manage another flight of stairs, but it is recommended that you move down stairs and either change the battery pack or recharge it with the quick charger supplied. In addition, an integrated beeper provides an acoustic signal to indicate that the battery charge is low. The beep frequency increases the lower the battery level.

4.1.5 Beeper function for correct transport angle

The stairclimber must be switched off to activate this function.

Press the main switch (1) for approx. 30 seconds. A short acoustic beep signal indicates that the function is now active. Repeat the procedure to deactivate this function.

While the beeper function is active an acoustic signal is given as soon as the stairclimber is no longer in the ideal stairclimbing angle.

4.2 UP/DOWN switch left and right on handle

The **UP/DOWN switch** is labelled with a neutral position (0) and two triangles pointing away from the operator (*forwards*) and towards the operator (*backwards*).

Down:
press triangle pointing **forwards**

Up:
press triangle pointing **backwards**

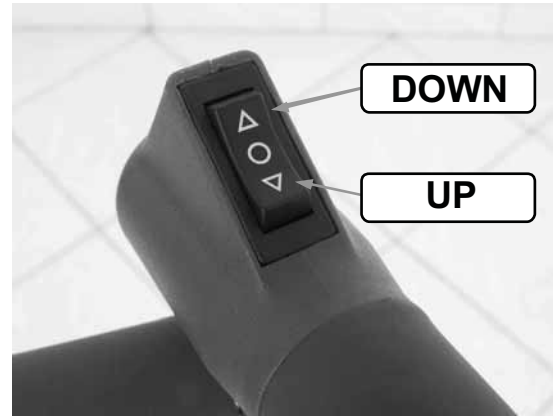

4.3 Clamping nut on adjustable handle

The clamping nut is captive (cannot be lost) and is designed to clamp the height-adjustable handle unit in place. The clamping nut features a special design that allows it to be tightened by hand. **It is not necessary to tighten the nut with force.** To find out how far the clamping nut should be tightened, Sano recommends rotating the nut clockwise with the handle positioned low down so that the operator can attempt to push the handle downwards using the weight of the upper body. Keep tightening the nut until the handle cannot be shifted. Very little force is applied to the handle while moving on steps since the stairclimber is balanced while in operation. The only time slight pressure is needed is while tilting the unit during loading and unloading. Loosening the clamping nut by one turn is quite sufficient for the handle to slide easily. The clamping range setting is adjusted using a concealed setting screw (*patented design*), which also acts as a safety screw and may only be adjusted by an approved workshop. There is no point in undoing the nut any further since the clamping range does not change. After approximately three turns the clamping nut is blocked so that it cannot be lost.

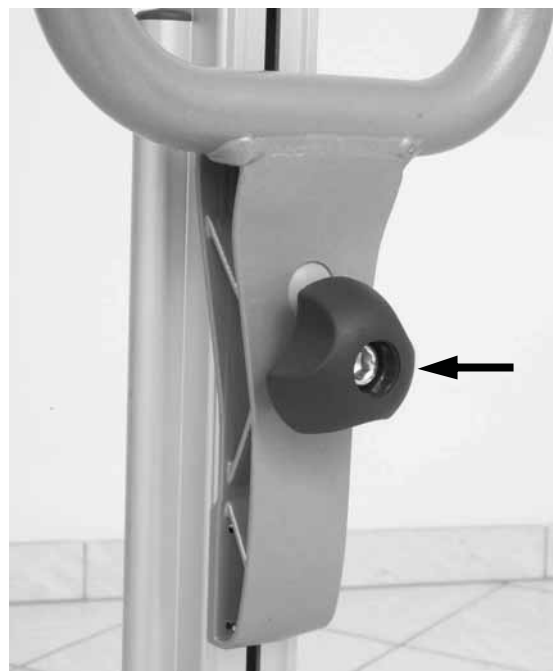

Note 1: *If the clamping nut cannot be undone, then it usually is already undone. Please check whether the handle slides freely up and down, or whether you can see a section of exposed thread between the nut and the handle.*

Note 2: *The following general rule applies for setting the height of the handle: The upper edge of the handle (where the UP/DOWN switches are located) should be at about the same height as the operator's shoulders (see also start-up section).*

5 Preparations to be made before you start

5.1 Climber unit, battery pack and handle unit

The following preparations need to be made to the Liftkar PT as a base unit:

1. Fit battery pack over the brown contact housing on the climber unit with the recess pointing towards the handle mounting socket (**photo 1**).
2. Insert the handle unit column into the battery pack recess (**photo 2**) and into the mounting socket. Press the handle unit down into the mounting socket until the lever screw on top of the control cluster is pressed upwards (**photo 3**).



3. Tighten the lever screw clockwise.
4. Switch on the main switch (LED display should light up green).
5. Select climbing speed I-II-III.

6. Test the brakes (**see section 9.4**).

7. **Experienced operators only:** if required, press mode switch 3 to switch from single-step mode to continuous mode.

Note:

The spindle is spring-loaded as it presses down onto the mounting socket. This design provides an extra degree of safety because the spring presses the handle unit column upwards if the spindle is not engaged properly, or is not tight enough. As a result there is no electrical connection to the control cluster (plug is disconnected between socket and column) and the Liftkar PT can no longer be switched on. The spring may not be strong enough to push the column upwards in all situations, but if the spindle is not engaged properly only a very slight movement of the column will cause the plug to disconnect so that the unit cannot be used on steps.

5.1.1 Adjust handle

The following general rule applies for setting the height of the handle: The upper edge of the handle (where the UP/DOWN switches are located) should be at about the same height as the operator's shoulders.

(See also section 4.3 about tightening the clamping nut)

5.1.2 Headrest (optional)

All models can be fitted with a headrest, available as an accessory.

Mounting the headrest is easy: just insert the two chrome rods into the holes on either side of the column underneath the control cluster and slide downwards. The height can easily be adjusted to the requirements of each individual passenger. The spring properties of the rods hold the headrest in any position without the need for a clamping system).

5.2 Additional preparations (depending on model)

The safety and comfort of the person being transported is of the highest priority while the stairclimber is in use.

Make sure you observe the safety instructions at the front of this manual and follow all recommendations made during training.

If any of the exceptional situations mentioned below do occur, please proceed as follows:

- If the passenger complains of feeling unwell or dizziness then stop the stairclimber and attend to the person.
- If the passenger generally has a problem with their back it is recommended that the slowest climbing speed is used.
- It is recommended that a headrest is fitted to support the neck muscles while the stairclimber is in the tilted position.
- The passenger should be relaxed and keep still while the stairclimber is in operation. It is essential that sudden jolts are avoided during operation.

5.2.1 Adjust seat position on Liftkar PT-S and PT-Outdoor models

On Liftkar PT models with an integral seat such as the PT-S and PT-Outdoor you just need to pull the seat up into place. The stairclimber is immediately ready for operation thanks to the self-locking scissor design.

All you need to do to fold the seat down again is to press the knobs forward on either side, or pull the upper scissor arm forward (**photo 1, 2 and 3**).

When the passenger leaves the Liftkar PT Sano recommends lifting the unit by pressing the UP/DOWN switch in the UP direction (*low speed*) (**photo 4**).

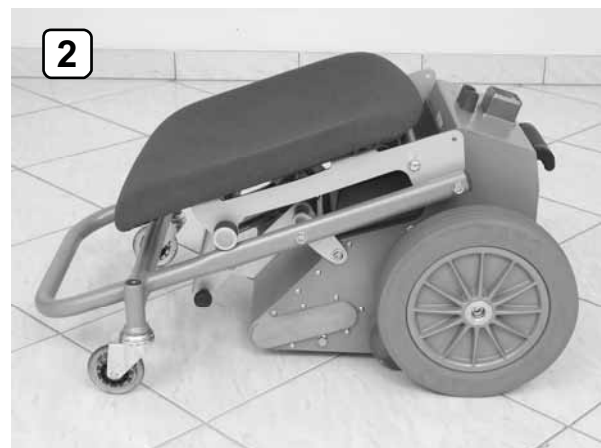



Leaving the Liftkar PT

5.2.2 Loading a wheelchair onto a Liftkar PT-Universal (general information)

The Liftkar PT-Universal enables you to transport any wheelchair up to a maximum width of 495 mm, measured at the back of the wheelchair (*including sports wheelchairs*) up stairs without any modifications to the wheelchair, and without removing its wheels.

The track width of the wheelchair should not exceed 730 mm (*measured on the outside of the wheels*).

Note 1: *with some wheelchairs it may be necessary to raise or remove any anti-tip devices. If the anti-tip devices are fixed then they will need to be modified to the removable or foldable type.*

The following preparations need to be made before starting:

- Assemble climber unit, battery pack and handle unit as described in 5.1.
- Fold down side platforms (**photo 5, part A**)
- Fold up rear stoppers (**photo 5, part B**)
- Adjust side platforms to the track width of the wheelchair
- Make sure that the retention bar with the clamps for the backrest of the wheelchair is properly mounted on the handle unit column. The stickers with arrows on the retention bar should point upwards.

Note 2: *The retention bar locks in place so that it does not slide downwards while no wheelchair is on the stairclimber. The retention bar is locked in place while it rests on the column. As soon as it is lifted the bar is unlocked and you can move it freely up and down the column (**photo 6 -7, see below**).*

Note 3: If the retention bar is retrofitted to the handle unit column note that the inside sliding blocks need to be rotated in a way so there is sufficient clearance to fit the bar to the rails down the side of the handle unit column. If a headrest is fitted this will need to be removed while the retention bar is fitted.

Note 4: Make sure that the wheelchair's parking brake is properly adjusted and in full working order. Especially on self-propelled wheelchairs (large wheels), safety is greatly increased when operating the Liftkar PT-Universal on stairs if the parking brake works effectively.

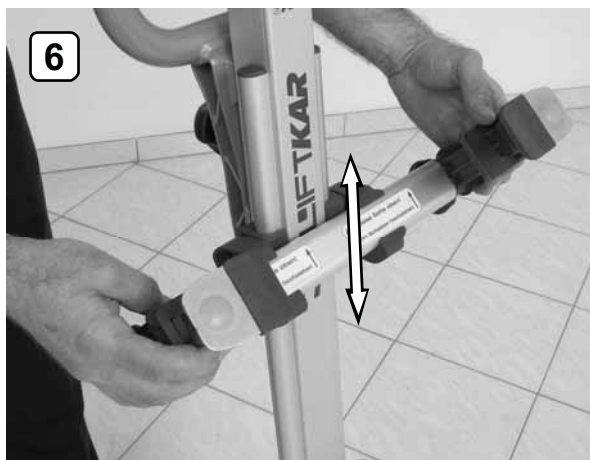
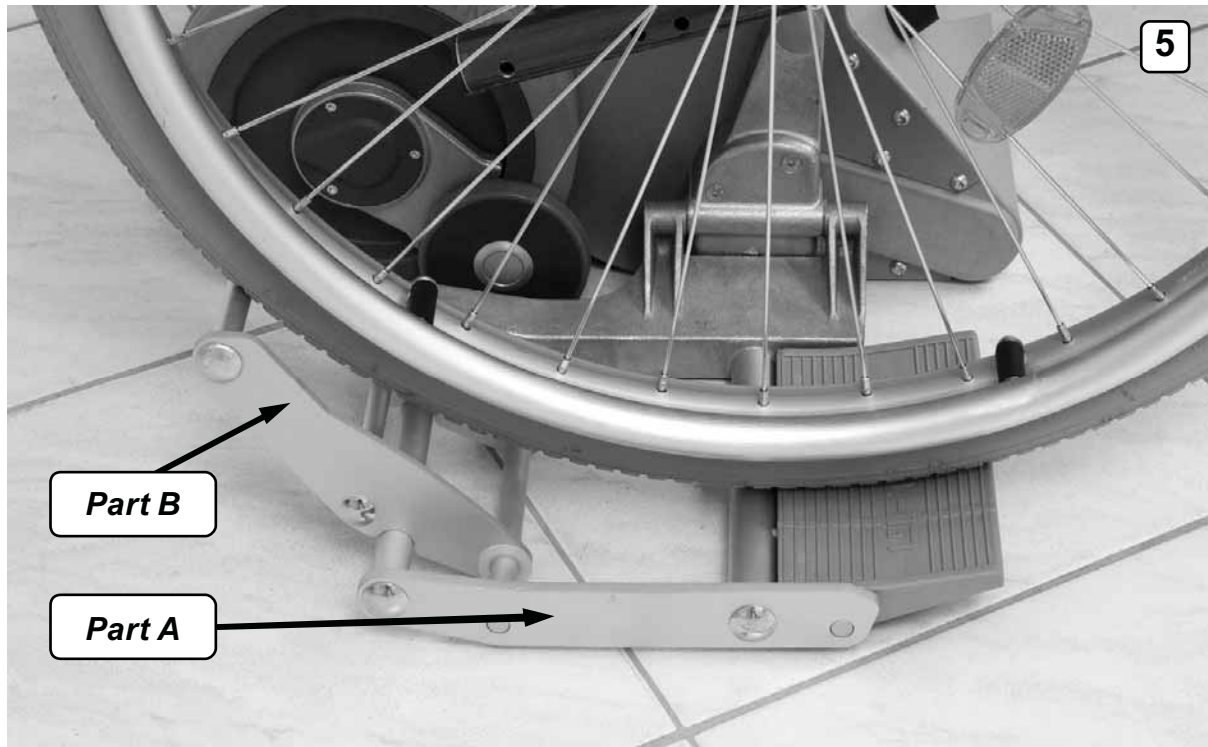

5.2.3 How to load a self-propelled wheelchair (PT-Universal)

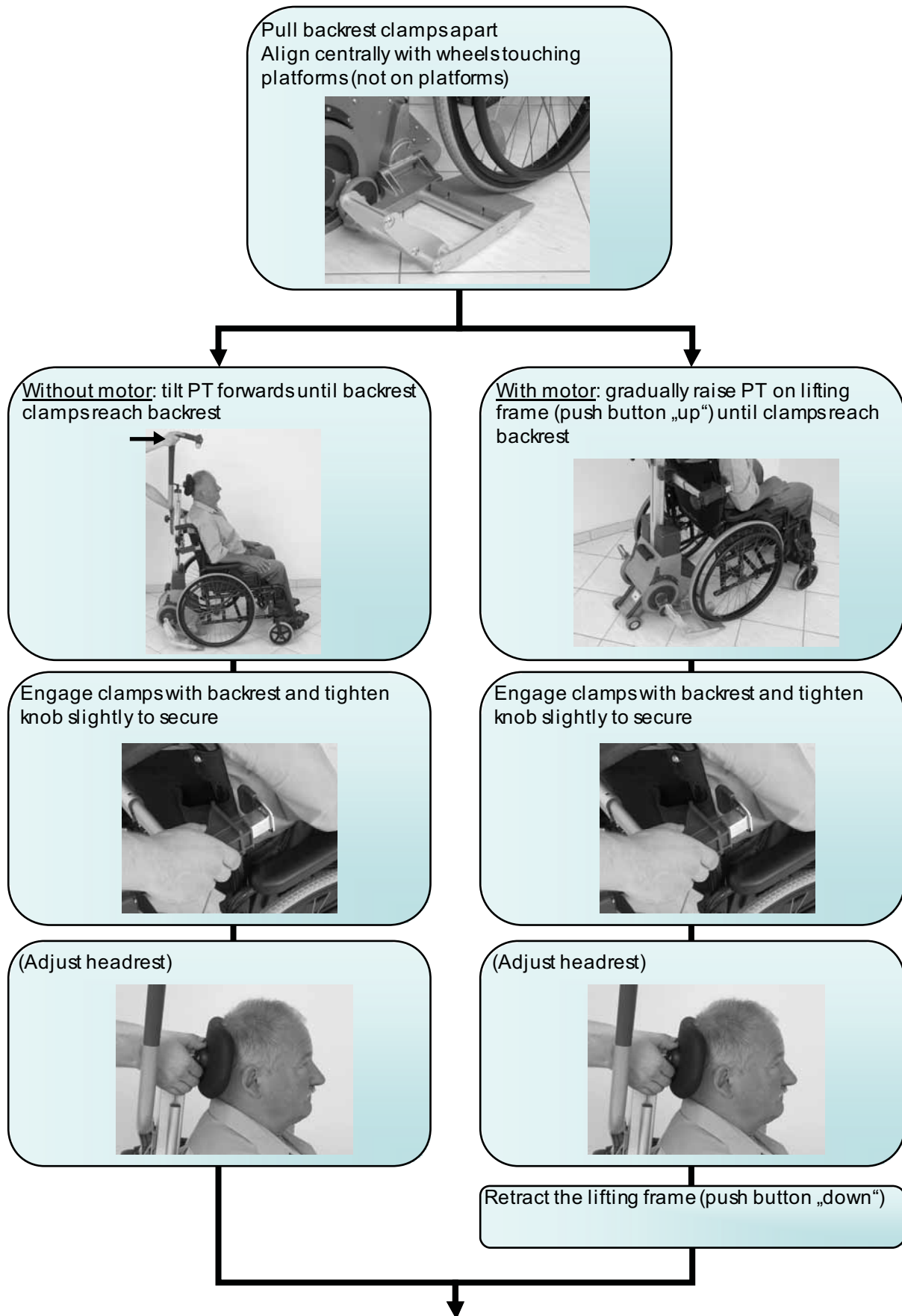



Tilt PT backwards



Pull wheelchair onto platforms with both hands



Tilt PT backwards while passenger reverses wheelchair onto platforms



Apply brakes to wheelchair wheels



Tilt PT back (into balanced position), and off you go



5.2.4 How to load a transport wheelchair (PT-Universal)

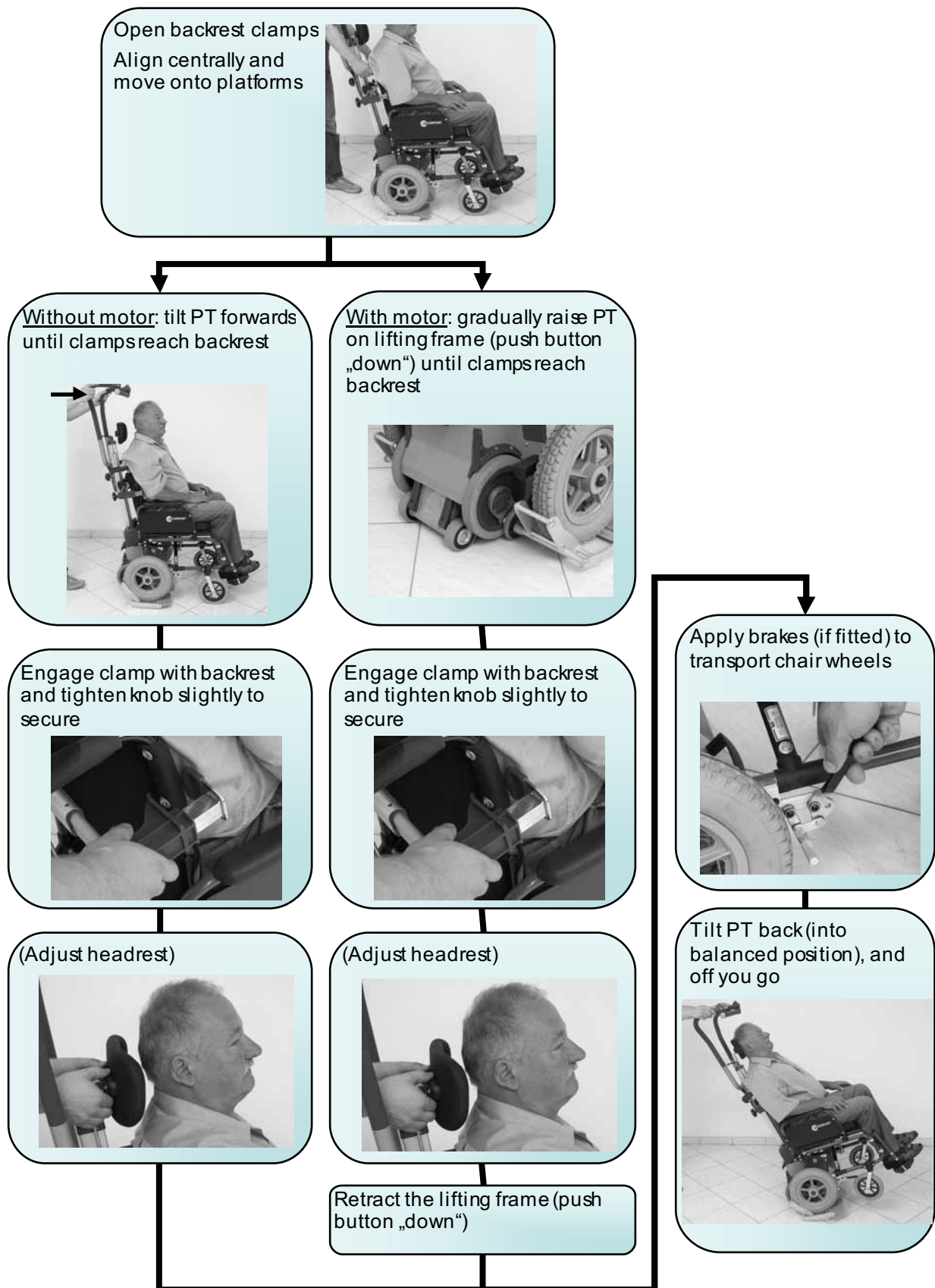

5.2.5 How to unload a self-propelled wheelchair (PT-Universal)

Tilt PT forwards until front wheels of wheelchair touch the ground



Tilt PT forwards with one hand and release backrest clamp on one side with the other hand



Now release backrest clamp on the other side



Tilt PT back until it rests on the ground



Release wheelchair brakes and move clear of PT



5.2.6 How to unload a transport wheelchair (PT-Universal)

Tilt PT forwards until front wheels of transport chair touch the ground



Tilt PT forwards with one hand and release backrest clamp on one side with the other hand



Now release backrest clamp on the other side



Tilt PT back until it rests on the ground



Release wheelchair brakes and move clear of PT



5.2.7 Loading a wheelchair onto a Liftkar PT-Plus and PT-Adapt

On both these models the stairclimber unit is secured to the wheelchair using an adapter mounting. (With the PT-Plus the adapter mounting is already fitted to the wheelchair supplied with the Liftkar PT and you just need to attach and detach the stairclimber as required).

With the Adapt model the customer needs to get a workshop to fit a special adapter mounting to the wheelchair.

These mountings are fitted to each side of the climber unit for anchoring axes with adjusting rings (*PT-Adapt, photo 1*) or with fixed axes (*PT-Plus, photo 2*)



How to attach the stairclimber to the wheelchair:

1. Lock the wheelchair wheels by applying the parking brake
2. Move the Liftkar PT under the wheelchair from behind as close to its centreline as possible and slide the lower rods into the lower mountings (*photo 3, arrow A on photo 4*).



Note 1: the lifting frame with support wheels should be centred between the wheelchair wheels so that the support wheels are not touching the floor (the lifting frame is in the correct position when it is stopped using the single-step mode control, see also 4.1.3)

Note 2: if the wheelchair had been folded for transport, make sure that it has been set up properly by simply pressing down sharply on the seat. **Otherwise it is possible that the side frames will not be far enough apart to allow the climber unit to fit between the lower mountings.**

3. Set the lowest speed (see also 4.1.2)

4. Press **UP** on the UP/DOWN switch so the climber unit moves upwards until the upper rods engage with the yokes on the upper mounting on the wheelchair (**photo 4**).

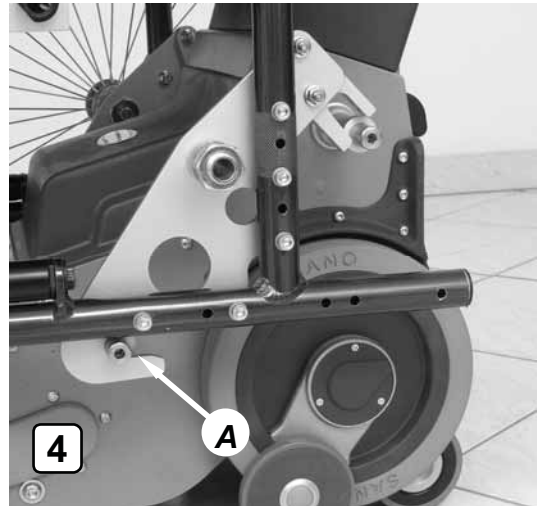

5. Use the quick-release pins to secure the mountings on the left and right (**photo 5**).



Note 3: quick-release pins are often used because they are self-securing due to spring pressure applied by an inside cone and three small balls which press outwards. Hold the mushroom head between forefinger and middle finger and press the spring pin down with your thumb. With the pressure released you can insert the pin into the hole on the mounting right up to the mushroom head. The quick-release pin locks in place when you let go of it. **Make sure the quick-release pin is working properly each time you use it.**

6. If you want to use the wheelchair/stairclimber, but not on the stairs, then press **DOWN** on the UP/DOWN switch so that the lifting frame retracts (the single-step control stops it in the right place automatically).

7. If you want to use the wheelchair/stairclimber on the stairs then press **UP** on the UP/DOWN switch so that the whole unit lifts upwards until the wheelchair wheels are clear of the floor. After releasing the parking brake on the wheelchair you must remove the wheels (otherwise there is a risk of causing an accident) and slot them into the holes located higher up on the PT-Plus (**photo 6 - 7**). Press **DOWN** on the UP/DOWN switch to lower the wheelchair plus stairclimber onto the Liftkar PT wheels. The unit is now ready for climbing stairs. (The next section (chapter 6) describes the stair climbing procedure in detail.)

Note 4: If the wheelchair wheels have been removed then it is also possible to move the wheelchair around on the Liftkar PT wheels. Note though that the handling is quite different from the large wheelchair wheels. Since the automatic step edge brake wheels are not able to clear obstacles higher than 15 mm in the forwards direction Sano recommends using the unit in reverse as much as possible.



5.2.8 Detaching the Liftkar PT-Plus and PT-Adapt from the wheelchair

1. First press **UP** on the UP/DOWN switch to raise the whole unit until there is enough space to fit the large wheelchair wheels (*remember to engage low speed*).
2. Insert the wheel axles into their sockets and apply the parking brake so that the wheelchair cannot roll away while the stairclimber is being detached.
3. Now you can remove the quick-release pins from the upper mountings (*hold the mushroom head between forefinger and middle finger and press the spring pin down with your thumb*).
4. Press **DOWN** on the UP/DOWN switch so that the lifting frame retracts (*the single-step control stops it in the right place automatically*). The stairclimber moves downwards away from the upper mountings to rest on its main wheels and can now be removed.

6 Operation on stairs

6.1 General instructions for operating on stairs

- Do not operate the stairclimber with a passenger on stairs unless you have received sufficient training and have practised using a Liftkar PT without a passenger, and then with a payload, such as a 20 litre water canister. Keep practicing until you no longer make any mistakes. Practise using continuous mode, but not until you have had some practice transporting a passenger in single-step mode.
- On PT-Adapt and PT-PLUS models it is essential you remove the wheelchair wheels, otherwise there is a risk of causing an accident. On PT-PLUS models the wheels can be slotted into holes higher up so they can be transported with the wheelchair. Try leaning the crossbar on your leg, hip or stomach (**see also 6.2**). Your body cushions the force that is applied when there is a change of load. You only need to use your arms and hands to stabilise and ensure that the stairclimber does not tilt forwards. Hardly any force is required if the operator is able to apply this method of operation. Please note though that it is essential that you always have one hand on the handle, even while the weight is leaning against you.
- The crossbar is better than the handle for adjusting the angle of the Liftkar PT. We therefore recommend that you have one hand on the crossbar and the other hand on the left or right handle (*with UP/DOWN switch*).
- If the passenger has a problem with their back it is recommended that the slowest climbing speed is used. The Liftkar PT lands more gently at this speed.
- Due to the tilted angle of the stairclimber during operation some passengers may need a headrest. This is available as an accessory (*see also section 5.1.2*) and is easy to fit.
- Normally, each flight of steps should be climbed without stopping. However, if it necessary to take a break, the stairclimber can be tilted backwards on the step. The safety brakes prevent the stairclimber from rolling down the stairs.
- Please check that the automatic step edge brakes function properly every time before using the Liftkar PT (*see section 9.4*).

6.2 Climbing UP stairs

1. Set the adjustable handle to the correct height (see 5.1.1 and 4.3)
2. Switch on the Liftkar PT with the main switch (if it is not already switched on).
3. Set speed selector switch to the lowest speed (I). (Do not select a higher speed until you have had some practice.)
4. Tilt the Liftkar PT towards you until it is balanced.

In the balanced position you only need a slight pressure to rock the stairclimber forwards or backwards.

Note 1: hold the crossbar with one hand, and the left or right handle next to the UP/DOWN switch with the hand that operates the switch. Normally right-handed operators operate the UP/DOWN switch with their right hand and have their left hand on the crossbar. For left-handed operators it is usually the other way round. (**photo 1**)



5. Move backwards to the stairs and stand on the second or third step, or stand with one foot on the second step and the other on the third step. Stand at a slight angle so that you can support the crossbar against the side of your body (**photo 2**). The main wheels of the climber unit must be touching the bottom step!

6. Now press on the UP/DOWN switch (on the arrow pointing towards the stairs, i.e. towards you). Make sure that you have one hand on the crossbar and the other hand free to operate the switch. (You only need to press one of the switches.)



7. The Liftkar PT now lifts upwards and the first thing you notice is a slight pull forwards which lasts for a few seconds. When the highest point is reached the Liftkar PT is balanced again. After the highest point has been passed the Liftkar PT moves backwards and gradually places its main wheels on the next step. Keep pressing the switch until the single-step mode control switches off the unit when the lifting frame and support wheels are fully retracted.

Note 2: *When the Liftkar PT moves backwards, shortly before it lands on the next step, the change in load applies a force to the rear, i.e. towards the operator. Try to cushion this pressure with the crossbar on your leg or hip. Your body cushions the weight. You only need to use your arms and hands to stabilise and ensure that the stairclimber cannot tilt forwards. Hardly any force is required if the operator is able to apply this method of operation. Please note though that it is essential that you always have one hand on the handle, even while the weight is leaning against you.*

8. Now you can move the Liftkar PT back to the next step and repeat the same procedure.

9. When you reach the last step the handle continues to rise because, although you have reached the end of the stairs, the stairclimber is still ascending. In places where there is not much space, on small landings for example, it is not always possible to keep the unit balanced because there may not be enough space behind you. To get around this problem it is necessary to tilt the Liftkar PT forwards - out of balance - so there will be a slight pull forwards. In such a situation Sano recommends placing the crossbar under your arm (**photo 3**) or sticking your elbow as a block through the handle uprights (**photo 4**). Using your arm as support you can draw the Liftkar PT very close to your body. Then you only need a very small area to turn and continue to the next flight of steps.



6.3 Climbing **DOWN** stairs

For moving **DOWN** stairs, Note 2 above relating to the use of the crossbar almost more important here than for moving **UP** stairs. When the lifting frame contacts the next step down a force suddenly acts backwards as described above. The passenger in the wheelchair feels this least if the crossbar is leaning against the operator's body. Another advantage is that your arms and hands hardly need to apply any force when using this method (**photo 1 and 2**).



For moving **DOWN** stairs the same starting procedure 1-4 applies:

1. Set the adjustable handle to the correct height (see 5.1.1 and 4.3)
2. Switch on the Liftkar PT with the main switch (if it is not already switched on).
3. Set speed selector switch to the lowest speed (I). (Do not select a higher speed until you have had some practice.)
4. Tilt the Liftkar PT towards you until it is balanced. In the balanced position you only need a slight pressure to rock the stairclimber forwards or backwards.

Note 1: hold the crossbar with one hand, and the left or right handle next to the UP/DOWN switch with the hand that operates the switch. Normally right-handed operators operate the UP/DOWN switch with their right hand and have their left hand on the crossbar. For left-handed operators it is usually the other way round. (**photo 1**)

5. Move gradually forward to the edge of the step until the step edge brake automatically stops the main wheels on the Liftkar PT (**photo 3**). Now press on the UP/DOWN switch (*on the arrow pointing forwards*). Make sure that you have one hand on the crossbar and the other hand free to operate the switch. (*You only need to press one of the switches.*)

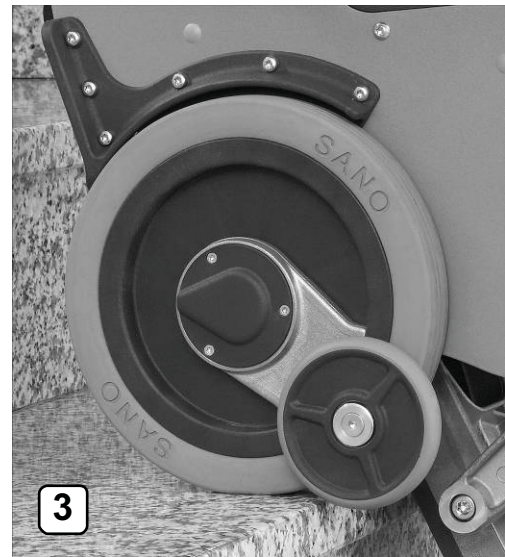

6. The lifting frame with its support wheels now extends to contact the next step down. As soon as the lifting frame touches the step with its support wheels the Liftkar PT raises slightly (*depending on the height of the step*), moves forward and lowers the climber gradually and in a controlled manner and stops in the neutral position in single-step mode.
7. Now you can move the Liftkar PT forward to the next step edge and repeat the same procedure.

6.4 Operation on spiral staircases

Please observe the following points when operating the stairclimber on spiral staircases:

- For moving **UP** start on the **outside** of the staircase. (*The Liftkar PT moves inwards when climbing **UP***)
- For moving **DOWN** start on the **inside** of the staircase. (*The Liftkar PT moves outwards when climbing **DOWN***)

If you do start moving too close to the banisters/wall then shift the unit to the side by reversing (*on a landing or wider step if possible*) and start again at a tighter angle.

6.5 Parking the Liftkar PT on the stairs

In an emergency the Liftkar PT can be parked on the stairs. The automatic step edge brakes prevent it from rolling away. However, for safety reasons it is important that you do not leave the passenger alone for any length of time.



6.6. Ideal transport angle

The Liftkar PT is equipped with an electronic transport angle supervision system. As soon as the stairclimber is no longer at the ideal angle the angle supervision system stops the climbing mechanism. If the angle is too low in relation to the steps then the LED in the control unit turns red as long as one of the UP/DOWN switches is pressed. The climbing mechanism cannot be activated again until the angle has been corrected.

If the angle of the stairclimber is too steep the angle supervision system also switches off the climbing mechanism. Pressing the UP/DOWN switch again causes the stairclimber to continue in creep mode.

6.7. Getting on and off the stairclimber

If the stairclimber is in an upright position, pressing one of the UP/DOWN switches causes the climbing unit to extend in creep mode. This function enables the person being transported to get on and off the stairclimber more easily.

This function also makes it easier to fit wheelchairs (PT Uni / PT Adapt and PT Plus). This function is always active independently of the climbing speed selected.

7 Operation on a ramp

If you use the Liftkar PT stairclimber to move up and down ramps, you can increase safety by activating the step edge brakes.

7.1 Moving DOWN a ramp

To move down a ramp you need to hold the Liftkar PT facing forwards; using the step edge brakes you can control the descent of the Liftkar PT (*with wheelchair*) by leaning the unit back until the brakes take effect.

7.2 Moving UP a ramp

To move up a ramp you need to hold the Liftkar PT facing backwards; using the step edge brakes you can control the descent of the Liftkar PT (*with wheelchair*) by leaning the unit back until the brakes take effect. The step edge brakes act like a reversing brake.

Note: *because the Liftkar PT is tilted backwards during operation it will not be possible to balance the unit. We recommend lengthening the adjustable handle beforehand so that the extra weight is easier to handle. Depending on the weight of the passenger and the length of the ramp it may be a good idea to have a second person available to assist.*

8 Charging the battery pack

The lead gel cells inside the battery pack are maintenance-free, gas-tight and rechargeable. Their service life depends largely on the number of charging/discharging cycles. For example, it is possible to partially discharge lead batteries 1000 times, drawing more than 200 times the full capacity of the battery, providing the battery is never fully discharged.

- Avoid discharging the battery completely. Charge the battery pack as often as possible.
- Lead batteries are susceptible to self-discharging. It is therefore necessary to recharge the battery pack after 3 weeks, even if it has not been in use.
- The charger unit switches over automatically to trickle charging so it is not possible to over-charge the battery.
- Do not leave the battery pack discharged or half discharged. Always recharge the battery immediately.
- If the batteries should become damaged it is possible to have them replaced in any reputable mechanical workshop. The old lead batteries are fully recyclable and are not to be disposed of.
- The ideal temperature for charging is between 20 and 25° C. Temperatures that are too cold or too hot will affect the battery's capacity.

Note: *if the battery pack is not fully charged, or it loses its charge suddenly, not only will the speed of the Liftkar PT be slower, but its capacity is reduced as well. This means that overload mode may be reached even with a relatively light load.*

8.1 Charger unit

The battery charger supplied is extremely powerful thanks to an automatic 2-stage system and digital control technology. The first stage is quick charging and the second stage is trickle charging for maintaining the charge. An LED display gives a clear indication of charging status. The charge indicator gives you an idea whether the battery pack is fully charged or not. It is worth checking that the battery pack is fully charged before using the Liftkar PT. If "trickle charging" is displayed it can be assumed that the battery pack is at least 90% full.



The charge status is displayed as follows by a red LED:

- If the LED is lit continuous red the battery pack is being charged quickly in the first stage. The battery pack is between 30 and 80% full.
- If the LED is flashing slowly then the charger has switched to trickle charging and the battery pack is between 80 and 100 % full.
- If the LED flashes very rapidly then it indicates that the battery pack has been discharged too far and is almost completely empty. Normally a "healthy" battery pack can be revived by the charger unit and after a certain time it will switch over to quick charging and the LED goes on continuously. Completely discharging the battery should be avoided as far as possible since the service life of the battery pack will be reduced.

As a rule "deep" discharges only happen if the battery pack is not recharged regularly between uses and the battery has no time to recover.

8.1.1 Technical data

Mains voltage supply(50/60 Hz, +/-15 %)	100-240 V AC
Nominal rating (input)	36 W
Charging voltage	24 V DC
Theoretical charging current	1.0 A
Protection class	IP40
Safety approval	GS and UL

8.1.2 Safety guidelines

- Protect against damp
- Only charge in a well ventilated room
- Do not pull the plug out of the socket by its cord

8.1.3 Use only for the purpose intended

- The charger unit is designed exclusively for charging **lead cell batteries containing liquid, gel-type and fabric-type electrolyte** (such as the battery pack supplied with the Liftkar PT).
- It is not permissible to charge NiCd or NiMH batteries or primary cells.

8.2 Mobile charger (optional)

This extremely powerful charger features an automatic 3-stage system using digital control technology. The first stage is quick charging and the second stage is for maintaining the charge. With a 3-stage system it is even easier to see how full the battery pack is.

Three different colours of LED on the casing of the charger unit provide a clear indication of the charging status (*the height of the bars show how full the battery pack is*).



8.2.1 Technical data

Inlet voltage	12 – 30 V DC
Power draw (no load)	approx. 2 W
Power draw (trickle charging)	approx. 5 W
Nominal rating	approx. 50 W
Charging voltage	24 V DC
Arithmetic charging current at 230 V / 50 Hz	approx. 1.3 A
Protection class	IP 30
Safety switch off after	3.3 h

8.2.2 Safety guidelines

- Protect against damp
- Only charge in a well ventilated room
- Do not pull the plug out of the socket by its cord

8.2.3 Use only for the purpose intended

- The charger unit is designed exclusively for charging **lead cell batteries containing liquid, gel-type and fabric-type electrolyte** (such as the battery pack supplied with the Liftkar PT).
- It is not permissible to charge NiCd or NiMH batteries or primary cells.

8.3 Connecting charger unit to battery pack

The battery pack can be charged separately or while it is mounted on the stairclimber. (see the two pictures below) The Liftkar PT is not ready for operation if the battery pack is being recharged on the stairclimber.

If you recharge the battery pack on the stairclimber, make sure you disconnect it from the charger before operating the Liftkar PT.



8.4 CE mark for charger units

The charger units fulfil the criteria laid down in the low-voltage and electromagnetic compatibility directive and are therefore designated with the CE sign.



9 Care, maintenance and transport

9.1 Maintenance

Liftkar PT stairclimbers are durable, low-maintenance products.

However, Sano recommends you have a check carried out at least once every two years on all moving components, electrical and mechanical connections, the quick-change battery pack and the charger unit. Please contact us for details of your nearest authorised Sano service centre!

Checklist of safety checks for Liftkar PT stairclimbers

Liftkar PT safety checks

Check	Interval	Comments	Checked by
Motor and casing			
Check/adjust tension of drive chain	every 2 years	max. play 2-3mm	
Check casing for cracks	every 2 years	Return stairclimber to manufacturer if cracks are detected	
Check bolts on casing and tighten	every 2 years	Loctite 243	
Check bolts on retention pins and tighten if required	every 6 months		
Check for running noise	permanently	Return stairclimber to manufacturer if noise becomes too loud	
Wheels and tyres			
Check mounting bolts for eccentric arm	every 2 years		
Check / clean brake contact surfaces	every 2 years		
Check tyres for damage and replace if required	permanently		
Brakes			
Check step edge wheels	every year	replace if required	
Check braking point	permanently		
Check brakes for ease of operation	every 2 years		
Check spring pins	every 2 years	tighten wheel hub to 23 Nm	
Electronics and control unit			
Check direction of travel and speed	every 2 years		
Check single step mode and continuous mode	every 2 years		
Check function of LED displays	every 2 years	Return stairclimber to manufacturer if defective	
Check battery pack, battery pack holder and connections	every 2 years		
Check battery pack and charger for mechanical damage	every 2 years	Return charger/battery pack to manufacturer if damage is detected	
Check thread on lever screw on handlebar unit	every 2 years	Return stairclimber to manufacturer if defective	
Accessories for PT Adapt, seat unit for PT S, guides on PT Universal			
Check all bolted connections and tighten if required	every 6 months	Replace immediately if cracks are detected	
Check all hinged points and lubricate if required	every 6 months	Replace immediately if cracks/damage is detected	
Check all accessories fitted and tighten if required	every 6 months	Replace immediately if damage is detected	

IMPORTANT:

In addition to the intervals described above, all safety checks must be carried out in full **each time there is a change of operator and each time the stairclimber is put into operation after a period of down time**, even if the stairclimber appears to be undamaged and operating normally at first sight.

9.2 Cleaning

Our motto is "A clean machine moves more smoothly". Cleaning with a standard household detergent is quite sufficient. Please do not use a high-pressure cleaner or similar.

It is important that the wheels – the rims and tyres – are kept clean **and free of grease** in order to guarantee full braking power.

The tyres on the main wheels are made of high-quality polyurethane and can be best cleaned of grease with brake cleaner or spirit.

9.3 Battery pack

The battery pack also needs to be looked after in that it must always be fully-charged. Completely discharging the battery will shorten its service life. Lead-gel cells (not nickel-cadmium) have a long service life if they are regularly fully charged as soon after use as possible. That is why the battery pack should be connected up to the charger unit after each use. (Read more on this subject in section 8, *Charging the battery pack*.)

9.4 Brakes and inside rims of main wheels

The braking effect of the main wheels is important and Sano therefore recommends that the brake components and rims are checked regularly for cracks or damage and cleaned if necessary. Please check the brakes after each cleaning. The easiest and most reliable method of checking the brakes is to tilt the Liftkar PT backwards at an extreme angle (the LED is then red). In this position it must not be possible to move the Liftkar PT forwards. Please test each brake separately by trying to free a brake on one side by turning the stairclimber sharply to the left or right. Please contact an authorised workshop if the brakes do not work well in this position.

9.5 Spares and repairs

Sano has issued authorised workshops with a complete list of all spare parts and the necessary exploded view drawings, repair instructions and special tools. If a repair is necessary then please contact Sano direct, or your nearest dealer. We will advise you immediately on how to get your stairclimber back into working order as quickly as possible. Please contact us for details of your nearest authorised Sano service centre!

9.6 Transport

The Liftkar PT can be dismantled into three parts (battery pack, climber unit, handle unit), or transported as a complete unit. Please make sure it is secured properly during transport.

9.7 Disposal

Liftkar PT stairclimbers are durable products. At the end of their useful life the stairclimber components and charger should be disposed of properly. Make sure the materials are separated carefully for disposal in line with the material codes relating to each component.

The stairclimber does not contain any hazardous materials and is fully recycling-compatible. The printed circuit boards and battery pack must be handed over to specialist recyclers.

Do not simply dispose of the battery pack in a household dustbin, however.

Sano can organise professional disposal of the whole stairclimber unit, against payment, if required.

9.8 Re-use / Second-hand use

Before re-using the stairclimber or using it second-hand, make sure it undergoes a safety check and cleaning as per Sano's instructions (ask Sano for a checklist) by specialist personnel.

All operators must have proof of having been trained in how to operate the stairclimber.

10 Troubleshooting

Problem: LED is red and stairclimber does not switch on

Cause: The stairclimber is at too flat an angle and the level switch is preventing it from switching on

Problem: The main switch does not work even though the handle unit is fitted.

Cause: The lever screw has not been tightened enough, or the handle unit is mounted back-to-front.

Problem: The climber unit does not run smoothly on the main wheels; it keeps on braking!

Cause: The lifting frame with the support wheels is not in its neutral position between the main wheels. Move forwards or backwards using single-step mode (see section 4.1.3) until the lifting frame stops in the neutral position.

11 Warranty and product liability

11.1 Warranty

The warranty period for the climbing unit and handle unit on all Liftkar PT stairclimbers is 24 months. Battery packs have a warranty period of 6 months. In both cases the warranty period starts on the day the product is handed over to the Customer.

The following are excluded from the warranty:

- wear parts
- damage that occurs from using the unit for a purpose it was not intended
- unauthorised modifications to the unit or accessories
- maintenance work required due to continuous operation
- faults occurring due to incorrect operation and/or failure to comply with the instruction manual, accidents, negligent or violent damage, damage due to fire and water, force majeure and other causes outside Sano's control.

11.2 Product liability

SANO Transportgeraete GmbH is not liable as manufacturer for any damage to the LIFTKAR PT:

- the Liftkar PT is used for a purpose for which it is not intended.
- the Liftkar PT is not maintained regularly by an authorised mechanical workshop, or by Sano.
- the instructions in this manual are not complied with.
- non-Sano components are fitted or linked to the Liftkar PT.
- original components are removed.

Please contact us for a list of authorised Sano service centres.

11.3 Declaration of conformity



SANO Transportgeraete GmbH takes sole responsibility in declaring that LIFTKAR stairclimbers comply with:

- the essential requirements of the EU directive for medical products 93/42/EEG, Appendix I
- the guidelines 2004/108/EEG relating to electromagnetic compatibility
- the applicable basic safety and health requirements of the EU guidelines for machines 2006/42/EG, appendix IIA

Any changes made to the product without our prior consent render this declaration void.

Relevant standards:

ISO 7176-23 Requirements and test methods for attendant-operated stair-climbing devices

EN 12182 Technical aids for disabled persons - General requirements and test methods

DIN EN ISO 14971 Risk analysis

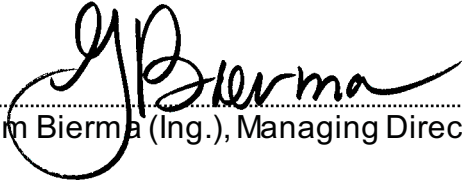
Jochum Bierma (Ing.), Managing Director

11.4 Registered patents

The climbing system is protected by international patents registered in Europe, USA and Japan. The handle unit is also protected by two patents. A patent is also registered for the wheelchair loading system featured on the Universal model.